

SC-F10000 Series

User self repair guide

Copyrights and Trademarks

No part of this publication may be reproduced, stored in a retrieval system, or transmitted in any form or by any means, electronic, mechanical, photocopying, recording, or otherwise, without the prior written permission of Seiko Epson Corporation. The information contained herein is designed only for use with this Epson printer. Epson is not responsible for any use of this information as applied to other printers.

Neither Seiko Epson Corporation nor its affiliates shall be liable to the purchaser of this product or third parties for damages, losses, costs, or expenses incurred by the purchaser or third parties as a result of accident, misuse, or abuse of this product or unauthorized modifications, repairs, or alterations to this product, or (excluding the U.S.) failure to strictly comply with Seiko Epson Corporation's operating and maintenance instructions.

Seiko Epson Corporation shall not be liable for any damages or problems arising from the use of any options or any consumable products other than those designated as Original Epson Products or Epson Approved Products by Seiko Epson Corporation.

Seiko Epson Corporation shall not be held liable for any damage resulting from electromagnetic interference that occurs from the use of any interface cables other than those designated as Epson Approved Products by Seiko Epson Corporation.

EPSON and EPSON EXCEED YOUR VISION or EXCEED YOUR VISION and their logos are registered trademarks or trademarks of Seiko Epson Corporation.





YouTube® and the YouTube logo are registered trademarks or trademarks of YouTube, LLC.

Contents

Copyrights and Trademarks.....	1
Contents.....	2
Notes on Manuals.....	3
Meaning of Symbols.....	3
Illustrations.....	3
Precautions for user self repair work.....	4
Important Safety Instructions	4
Workflow.....	5
How to activate user self repair mode.....	6
Diagnosis of parts.....	7
How to replace parts.....	9
What You'll Need.....	9
Handling of parts.....	9
Anti-drying cap	9
Print head.....	9
How to replace the anti-drying cap.....	12
Removing the anti-drying cap.....	12
Installation of anti-drying cap	14
How to replace the printhead	15
Printhead removal.....	15
Printhead installation.....	19
Ink filling and printhead adjustment after replacement.....	23
Disposal of used parts	25
Disposal of anti-drying cap	25
Printhead disposal	25
Packing method.....	25
Problem solver	26
When a message is displayed.....	26
Troubleshooting	27
Media jams.....	27

Notes on Manuals

Meaning of Symbols

 Warning	Indicates that there is a risk of death or serious injury if the product is ignored and handled incorrectly.
 Caution	Indicates that there is a possibility of personal injury or property damage if the display is ignored and handled incorrectly.
 Important	It describes the contents that must be protected. Improper handling by ignoring this content may cause product failure or malfunction.
Note	Provides supplementary explanations and reference information.
	Indicates where to refer to related content.

Illustrations

The illustrations (including photos) shown may differ slightly from your model. Please note.

Precautions for user self repair work

Do not perform user self repair work unless you have taken the user self repair training.



Do not use the user self repair mode or replacement parts except in the following cases.

If the print result is abnormal, cleaning around the print head, cleaning the anti-drying cap, and [Print Head Refresh] do not improve.

Important Safety Instructions

This explains what you must do to safely perform user self-repair work and prevent damage to workers and other people and property damage. Be sure to also read the " Important Safety Instructions" described in the "Start-up Guide" (booklet).

Handling precautions

 Warning	
	Do not replace the anti-drying cap or print head unless you have taken the user self repair training. There is a risk of injury or electric shock.

Workflow

Follow the steps below to perform user self repair.

Parts replacement will be carried out after diagnosing the parts if the abnormal printing results are not resolved even after maintenance. If the print result is abnormal, start the maintenance as shown below and start the action.

1. Perform maintenance.

Take corrective action in the following order until the error is resolved. If the abnormality is resolved, parts need not be replaced.

- Cleaning the print head
- Cleaning around the print head
- Cleaning of anti-drying cap
- [Print Head Refresh] (2Times)
- On setting for [Nozzle Compensation]

For details on maintenance, refer to "User's Guide"(Online manual).



2. Set the media.

Set Enhanced Matte Paper 24".

The user self repair function is designed based on this media. You have to set the media.

For details on how to set, see "User's Guide" (online manual).



3. Turn on this printer in the user self repair mode.

When you turn off the power of this printer and start it in the user self repair mode, you can use the function of diagnosing and replacing parts.

→ ["How to activate the user self repair mode"](#)



4. Diagnose the part.

Diagnose if parts need replacement.

The diagnosis cannot be executed unless [Print Head Refresh] is executed twice and [Nozzle Compensation] is set to ON. Please do it in advance.

→ ["Diagnosis of parts"](#)



5. Replace parts.*

Replace the anti-drying cap or printhead depending on the diagnostic results.

After replacing the print head, fill the ink and adjust the print head.

→ ["How to replace parts"](#)



6. Turn on the printer in normal mode.

*The procedure can be viewed as a video on YouTube. ([Video Manual](#))

How to activate user self repair mode

When you start the unit with the following procedure, it will be in the user self repair mode.

- 1** Make sure the printer is turned off.
- 2** While holding down both media operation buttons, press and hold the power button until the screen shown in the figure appears. (About 25 seconds)

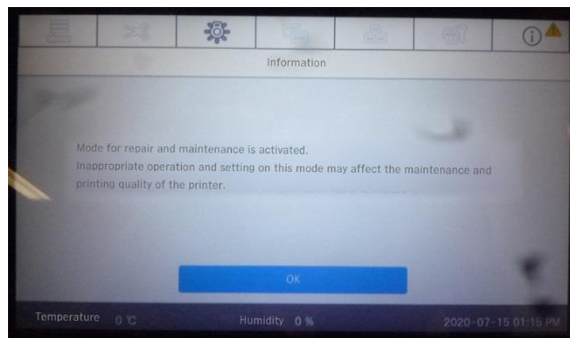

If the screen as shown is not displayed and the power turns on normally, turn off the power and try again.

Diagnosis of parts

Use the diagnostics feature to diagnose if a replacement is needed. Please follow the steps below.

Diagnosis of parts cannot be executed unless the following maintenance is performed. Please do it in advance.

- Perform [Print Head Refresh] twice.
- Set Nozzle Compensation to ON.

1 From the Home screen, press  (Maintenance), then [Repair menu]-[Diagnosis].

2 Press Start.

3 Confirm the displayed contents and press [Next].

Diagnosis of parts begins.

If [Next] is not displayed, necessary maintenance has not been performed in advance. Click [Close], perform maintenance, and then perform diagnosis again.

4 Check the diagnostic result.

After diagnosis, the first screen will indicate if parts need replacement.

- [Error was not detected. Contact Epson Support if necessary.] is displayed, it is possible that the cause is something other than a component error. Please contact your dealer or Epson Support.
- If a printhead number such as [Head 5] is displayed, the printhead with that number needs to be replaced.

Press Check Details to view detailed parts cleaning and replacement information.

If you select the [Anti-Drying Caps Diagnostics Result] tab, the anti-drying cap that needs to be cleaned or replaced will be displayed in a solid color.

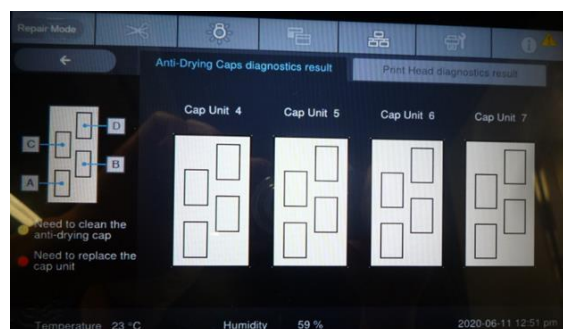

When you select the Printhead Diagnostics Results tab, the anti-drying caps that need cleaning and the printheads that need replacing are shown as filled.

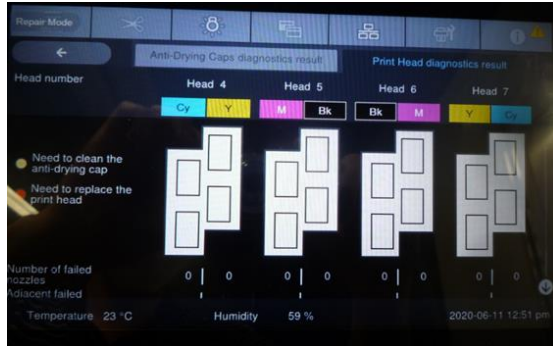

The following information is displayed at the bottom of the printhead graphic.

- Number of failed nozzles
- Number of adjacent faulty nozzles
- Printhead installation date

Adjacent faulty nozzles cannot be complemented for missing nozzles. Use this as a reference when deciding whether to replace the printhead.

Refer to the "User's Guide" (online manual) and clean the anti-drying cap that needs cleaning.

If parts need replacement, follow the procedure in the next section.

How to replace parts

What You'll Need

Use the following during replacement work.

New replacement parts

Prepare the anti-drying cap or print head according to the diagnosis result.

Phillips screwdriver (commercially available) (only when replacing the anti-drying cap)

Used to attach and remove the anti-drying cap.

Gloves (included with replacement printhead), protective glasses (commercially available)

Prevents waste ink from getting on your skin or getting in your eyes.

Handling of parts

Anti-drying cap

Precautions for storage

- Do not remove it from the protective case until you replace it. Fluff and dust may adhere.
- Please keep away from direct sunlight.
- Do not store in a place wet with water.

How to hold

Hold the side as shown and do not touch the cap.

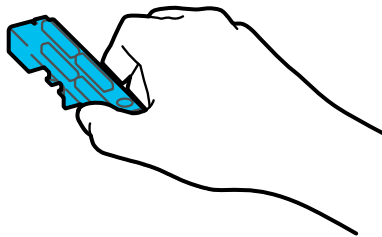

Print head

The print head is a precision part.

Follow the procedures and precautions in this manual when handling.

Precautions for storage

- Do not open the outer box or protective case until the replacement work is performed. Fluff dust or dust may adhere to the nozzle surface or ink supply holes.
- Store in the following environment, avoiding direct sunlight.
- -20°C-60°C (no condensation)
- Do not store in a place wet with water.
- Be sure to keep the vertical direction correctly when storing.
- When stacking boxes, put up to three.

Notes on opening

- Check the vertical direction before opening.
- The outer box, plastic bag, and protective case are used for packing when collecting used printheads. Please open it carefully without breaking it.
- Do not open the protective case until the print head is replaced. Fluff dust or dust may adhere to the nozzle surface or ink supply holes.

How to open and take out

Open

Follow the procedure below to open the package.

- 1** Open the printhead protective case.



- 2** Insert your finger into the recess next to the printhead and remove the printhead.

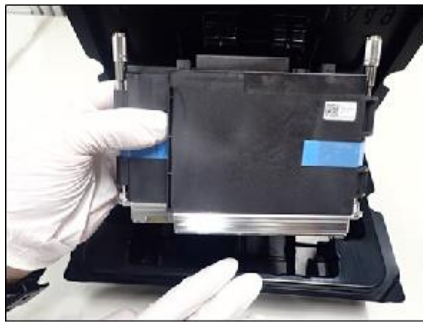

- 3** Peel off the two tapes.

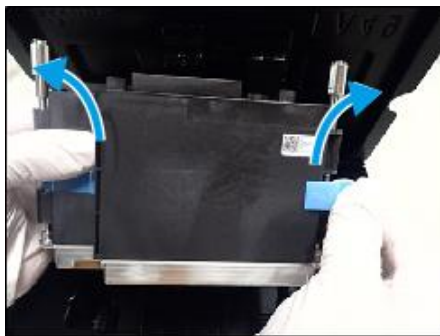

- 4** Replace the printhead in the protective case.



take out

Hold the print head fixing screw head when removing it.

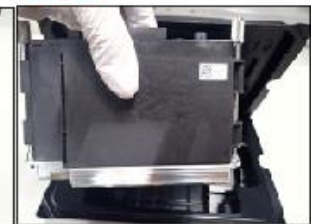
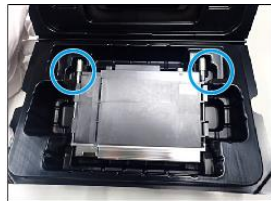

How to replace the anti-drying cap

Removing the anti-drying cap

- 1 From the Home screen, press  (Maintenance), then [Repair menu]-[Replace anti-drying cap].
- 2 Check the cap to be replaced and press [Start].

The caps that need to be replaced are shown filled. Check all caps to be replaced.

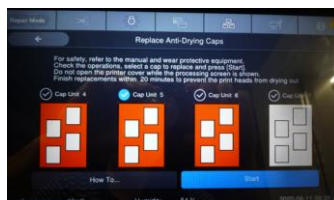

Press Start to move the printhead to the right.

- 3** While lowering the lock release lever, open the left maintenance cover.

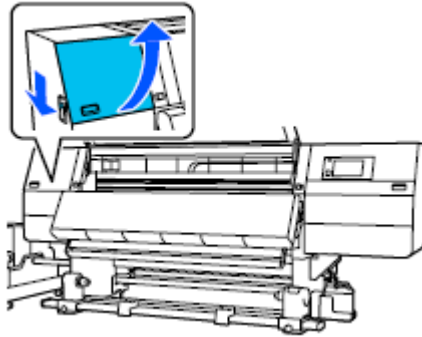

- 4** Loosen the screw in front of the cap with a Phillips screwdriver and remove it.

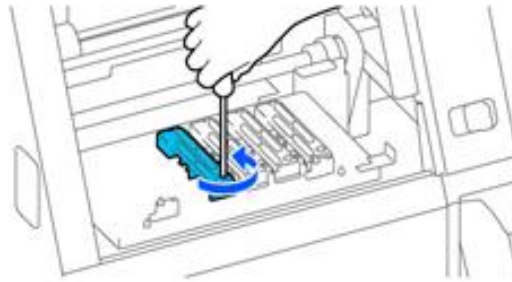

- 5** Lift and remove the front side of the cap.

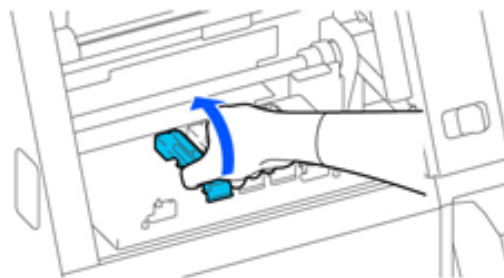

- 6** Put the used cap in the bag that contained the new cap to prevent ink from getting around.

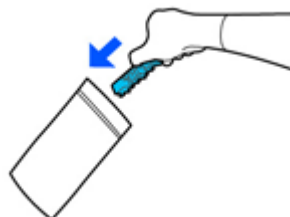

Installation of anti-drying cap

- 1** Take out the new cap and remove the cover.



- 2** Attach the cap to the printer.

Insert the protrusion on the back side of the cap into the hole of the printer as shown in the figure to attach it.

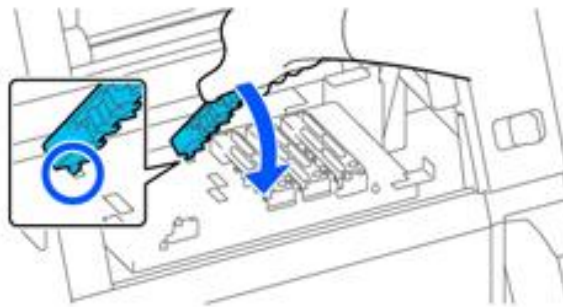

- 3** Install and tighten the screw in front of the cap.

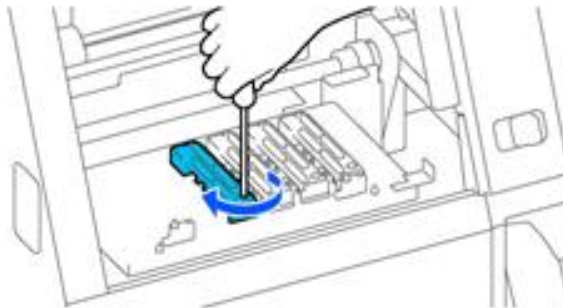

- 4 Close the maintenance cover and press [OK].

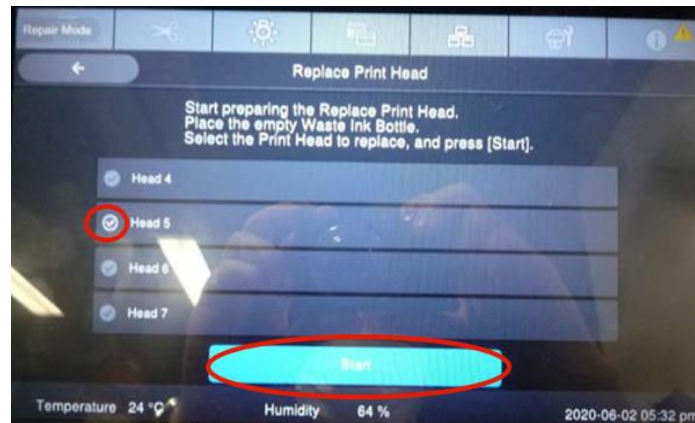

This completes the replacement work of the anti-drying cap.

How to replace the printhead

You can watch the video on YouTube.

[Video Manual](#)



Important

Please complete the replacement within 30 minutes. If you work for a long time, the ink may solidify and the nozzle may be clogged.

Printhead removal

- 1 Make sure the media is loaded, then from the Home screen, press  (Maintenance), then [Repair menu]-[Replace Print Head].
- 2 Check the printhead displayed in step 4 of the diagnosis and press [Start].

Check all printheads that will be replaced.
The figure is an example of checking Head 5.
- 3 Check the screen display and clean the suction cap.

See the following for details on cleaning methods.
→ "User's Guide" (online manual)

When you have finished cleaning, press [Complete].

- 4** Check the display on the screen and press [Start].

The operation of discharging the ink from the print head starts.
Ink discharge will be completed in about 4 minutes and the screen display will change, so proceed to the next step. "

- 5** Check the display on the screen and turn off the power of this printer.

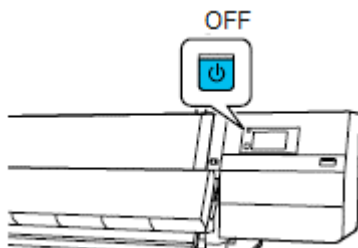

- 6** Move the left and right lock levers outward to open the front cover.

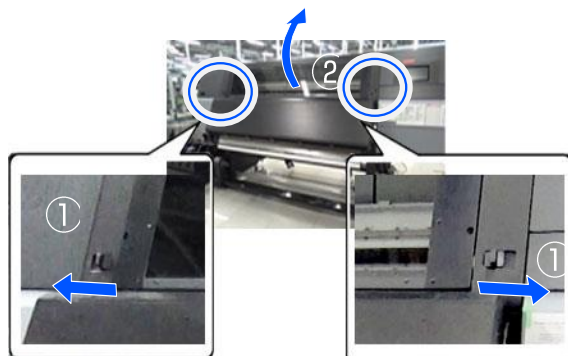

- 7** Remove the four screws on the front of the printhead.

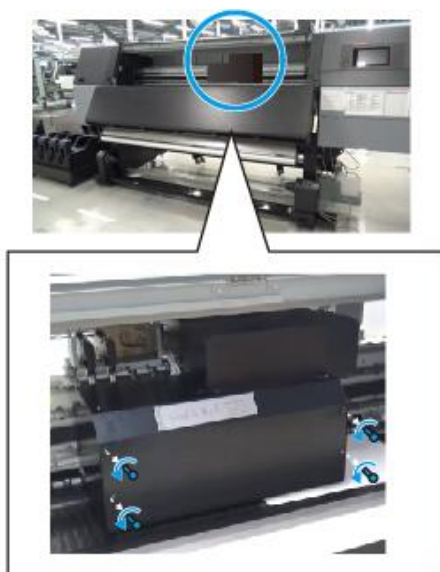

- 8** Remove the two screws on the upper left and right sides.

The Y-type terminal will come off.

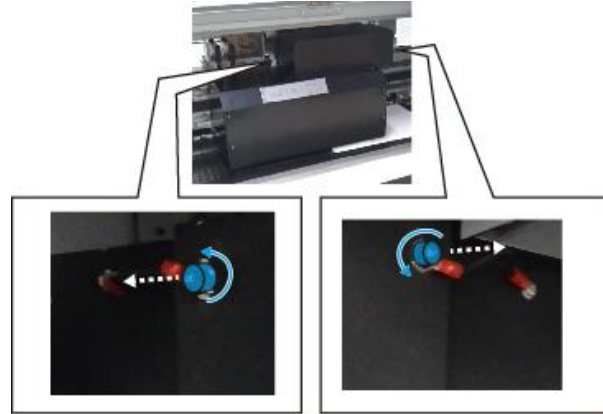

- 9** Loosen the 4 screws on the left and right sides by 3 turns.

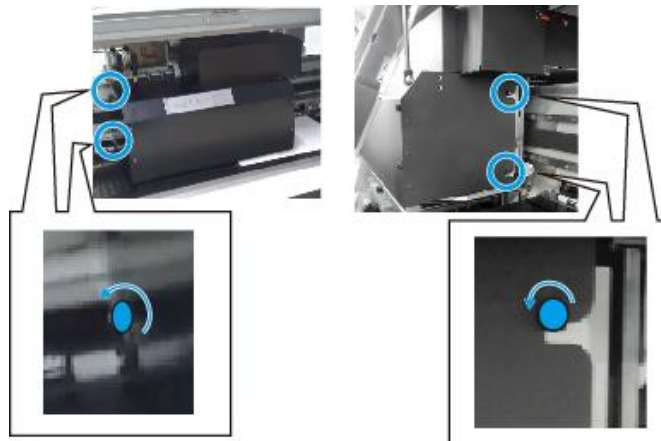

- 10** Lift the printhead cover slightly and remove it toward you.



- 11** Completely loosen the two screws on the connector at the top of the printhead.

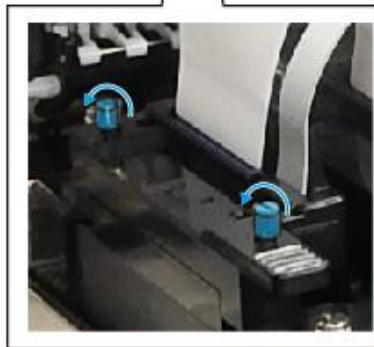
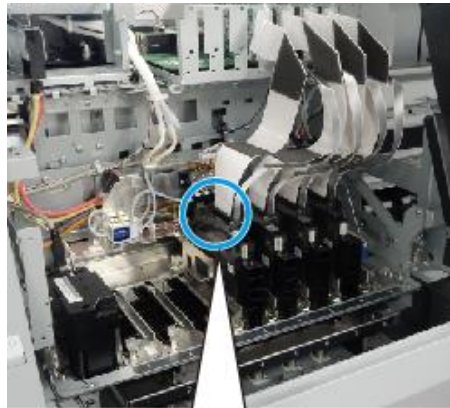

- 12** Pull the connector straight out and put it in the back.

Hold the connector, not the cable, when pulling it out.

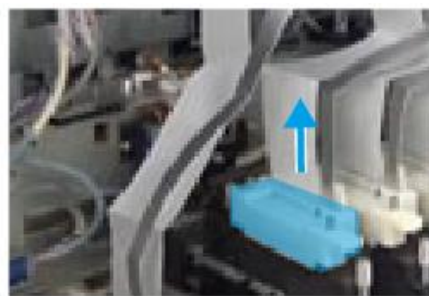

13 Completely loosen the two fixing screws on the printhead.

If it is difficult to loosen with your hand, use a commercially available Phillips screwdriver to loosen it.

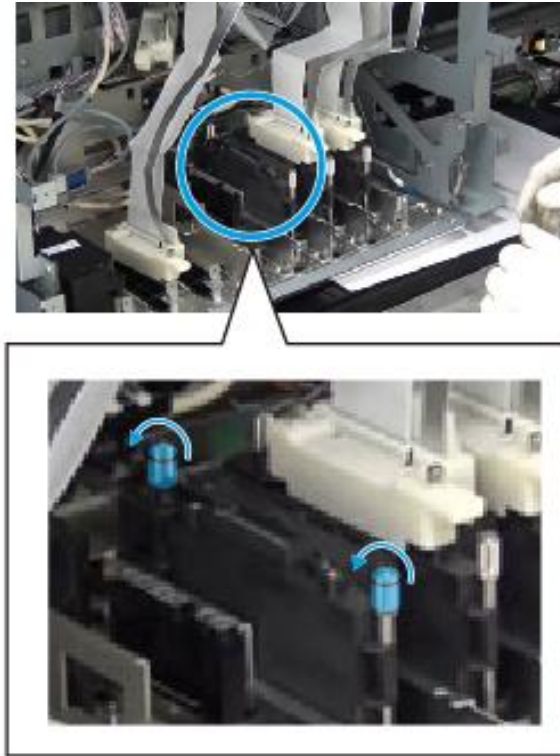

14 Hold the head of the screw and pull the printhead straight up.



Printhead installation

1 Remove the new printhead from the case.

Hold the print head fixing screw head when removing it. Also, carry out the following procedure while holding the head.

[→ "How to open and take out"](#)

2 Insert the printhead straight down along the front guide.

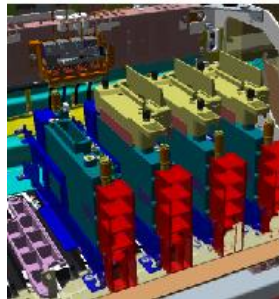
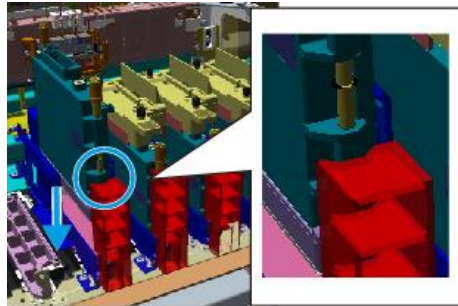

Make sure that the protrusion fits into the positioning hole at the bottom of the print head when you insert it all the way down.

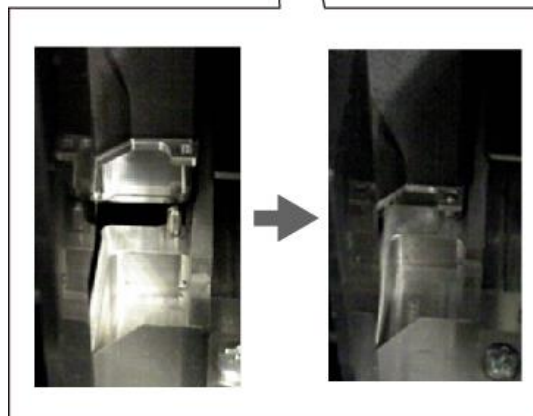
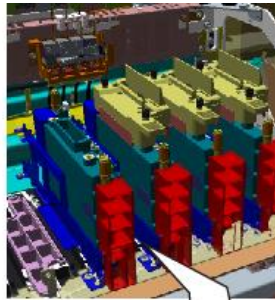

- 3** Press in on the top of the printhead and insert it firmly.

Please push the  part of the figure.



- 4** Tighten the fixing screw firmly.

Tighten with a torque of 0.3 Nm or more.

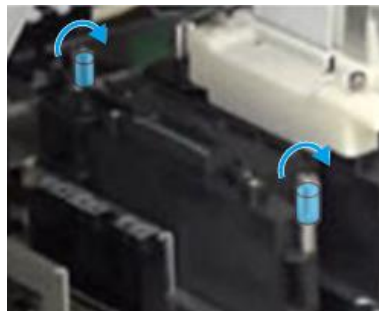

- 5** Insert the connector straight.

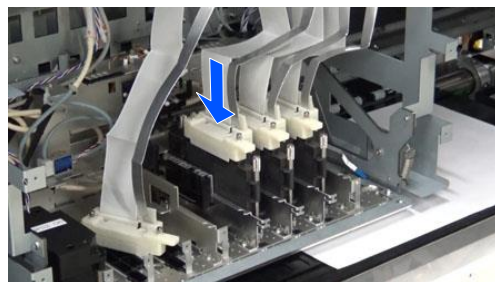

6 Tighten the connector screws.

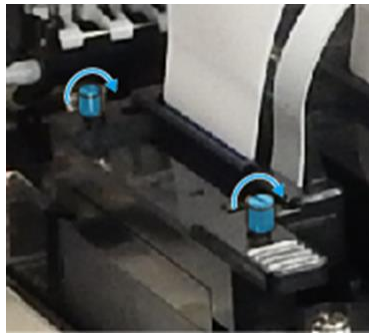

7 Install the printhead cover.

Attach the notches on the left and right sides of the cover so that they are hooked on the screws.

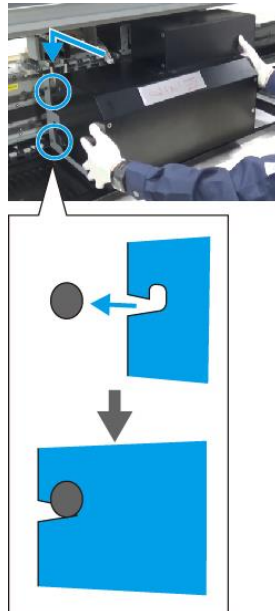

8 Tighten the four screws on the left and right sides.

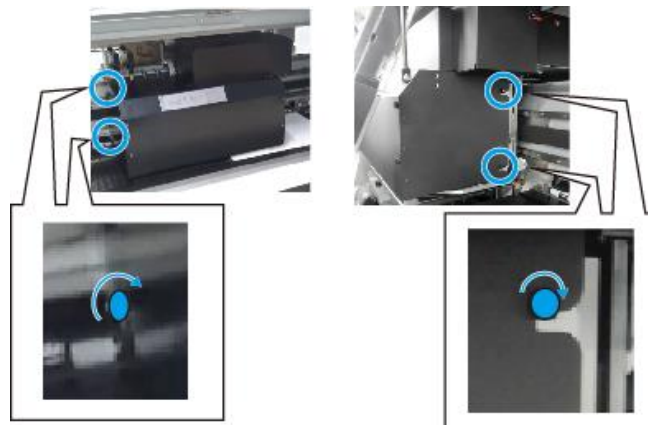

- 9** Tighten the two screws on the top of the left and right sides after attaching the Y-type terminal.

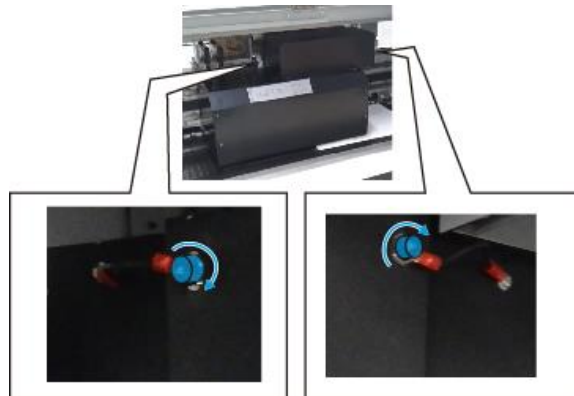

- 10** Tighten the four screws on the front of the printhead.



- 11** Close the front cover and move the left and right lock levers inward.

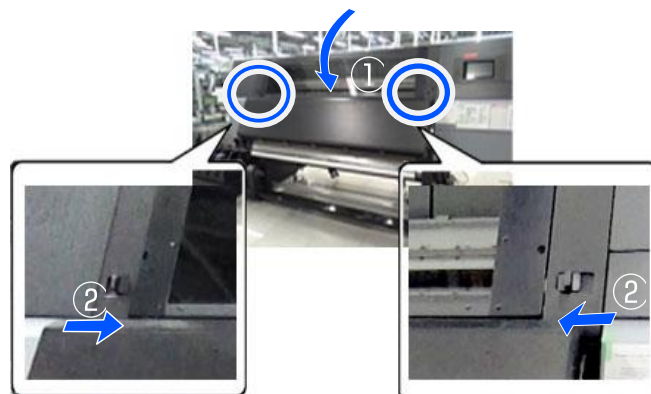

Ink filling and printhead adjustment after replacement

- 1** Start the printer in the user self repair mode and fill the ink.

See below for details.

→ ["How to activate the user self repair mode"](#)

When starting in the user self repair mode, ink filling will start automatically. Ink filling will be completed in about 15 minutes and the screen display will change, so proceed to the next step.

2 Print the nozzle check pattern.

Set the saving mode and press [Start] to start printing the pattern. When printing is complete, the screen display will change, so proceed to the next step.

See the following for details on the saving mode.

→ "User's Guide" (online manual)

3 Check the print result.

If the check pattern is not missing, press [OK].

If the check pattern is missing, press [NG] to clean the print head.

4 Print the printhead alignment pattern.

When you press [Start], pattern printing starts and the print head is adjusted automatically. The adjustment will be completed in about 15 minutes and the screen display will change, so proceed to the next step.

5 Check the display on the screen and press [OK].

This completes all printhead replacement work.

Disposal of used parts

Disposal of anti-drying cap

Dispose of the used anti-drying cap in the bag that contained the new cap.

The used anti-drying cap is industrial waste. Please dispose of in accordance with the law, such as entrusting waste disposal to an industrial waste disposal company. When consigning, submit the Safety Data Sheet to an industrial waste disposal contractor. —

You can download it at your local Epson Web site.

Disposal of printhead

Contact your dealer or Epson Support to dispose of used printheads.

When disposing, use the following procedure to pack the used print head so that ink will not leak during transportation.

Packing method

- 1 Place the used printhead in the protective case with the orientation shown and close the lid.

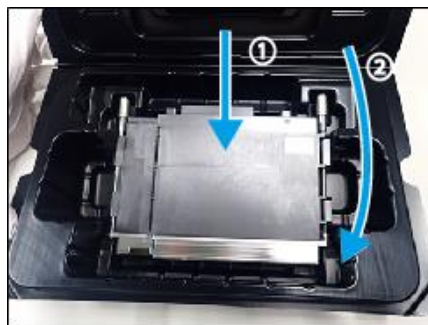

- 2 Put the protective case in the plastic bag or outer box where the replacement print head was packed and seal it with adhesive tape.

Pack it securely so that the print head does not come out of the outer box during transportation.

Problem solver

For details on how to deal with this, see the "User's Guide" (online manual).

When a message is displayed

If one of the following messages is displayed, read and follow the instructions below.

Messages	What to do
The waste ink bottle is nearing the end of its service life. Prepare a new one. You can continue printing until replacement is required.	The Waste Ink Bottle is getting full. Ready a new Waste Ink Bottle.
Ink cartridge is not recognized. Please replace the cartridge.	Remove and reinsert the ink cartridge. If the message persists, insert a new ink cartridge (do not reinsert the ink cartridge that caused the error).
Ink is low You can continue printing until replacement is required.	The ink is low. Confirm that a new ink cartridge is installed so the ink cartridges can be automatically switched when the remaining amount falls below the threshold.
The media and print head are contacting. Check whether the print results are clean. Printing can continue.	If you check the print results and they are dirty, stop printing and clean around the print head. At the same time, refer to "Troubleshooting & Tips" in the Online Manual to take measures so striking does not reoccur.
The XXXXX is nearing the end of its service life.	The replacement interval is approaching for the parts that are shown. Prepare new parts.
The media is not attached to the roll core on the auto take-up reel unit. Attach the media.	Media is not correctly attached to the Auto Take-up Reel Unit. If this happens while printing, press Suspend to stop printing. Turn the Auto switch on the Auto Take-up Reel Unit to Off temporarily, return it to the original settings, and then correctly install the media to the Auto Take-up Reel Unit.
The roll core is spinning. Remove the media from the media holder, and then reload the media.	Media is not correctly attached to the Media Feeding Unit. Remove the media, and then correctly attach the media to the Media Feeding Unit.
The inside of the printer is hot. Lower room temperature.	Lower the temperature of the room until it is within the temperature range described in the "Specifications Table".
The media is low.	The remaining amount of loaded media is running low. Prepare new media.
The media is not loaded correctly. Raise the media loading lever and remove the media. Then reload the media.	Media was not correctly loaded when it was loaded. Refer to the following, and load the media correctly.
[XXXXX] is different from the winding direction of the loaded roll media. Set it to match the winding direction of the loaded roll media.	Shows the winding specifications that were set in XXXXX when loading media. Does the Roll Winding Direction set when loading media match the actual winding specifications?

	Raise the media loading lever to resolve the error. Lower the media loading lever again, and follow the on-screen instructions of the printer to reset the Roll Winding Direction correctly. The error is released when the media set lever is raised. Lower the media set lever again, and set [Roll winding direction] correctly according to the instructions on the screen of this printer.
Cleaning the Anti-Drying Caps.	The anti-drying caps are dirty and need to be cleaned. Follow the on-screen instructions to check and clean the caps that need cleaning.

Troubleshooting

Media jams

■ **Is media curled, folded, curved, creased, or waved?**

Cut and remove the curled, folded, curved, creased, or waved part.

■ **Is media loaded just before printing?**

The pressure rollers may crease media left in the printer, or the media may also become wavy or curled.

■ **Is the media too thick or too thin?**

- Check the media specifications to determine whether it can be used in the printer.
- For the setting method when printing using software RIP, refer to the RIP manual.

■ **Is Paper Suction set too high?**

In the media settings, reduce Paper Suction (the force that sucks media down the media path).